



AMERICAN PRIME MFG. INC.

7310 Adams St. Ste. G.

Paramount, CA 90723

info@apminc.us

www.americanprimemfginc.com

REMOVING THE BEARING FROM THE APM 1056-0002 Comp Master™ CLUTCH

NOTE: This is the suggested method to remove the bearing without damaging any part of the assembly. You will need to fabricate the few tools needed to press out the bearing. These are not parts sold through APM Inc.

Use old early aluminum primary belt clutch basket if available.

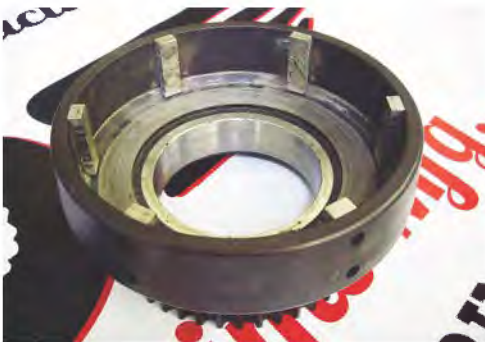

Hub & Carrier separated from clutch



Drop hub & carrier into basket



Flip Basket over and install locking flange



Thread six 10-32 x 3/4" bolts through flange into aluminum bearing carrier.



Hub installed in basket ready for hydraulic press.



Raise and support the basket so that the hub will be able to 'free fall' from the bearing once it is pressed out.



Use a piece of steel bar that is slightly smaller than the OD of the hub snout to press out the hub

Using a hydraulic press, slowly put pressure on the steel bar, forcing the hub downward and out.



Hub removed from bearing.



Now machine a steel bar so that the end is slightly smaller than the ID of the bearing and stepped so that the middle of the steel bar is slightly smaller than the OD of the bearing area that is visible.

Place the steel bar on top and into the ID of the bearing.



Using a hydraulic press, slowly put pressure on the steel bar, forcing the bearing downward and out of the aluminum bearing carrier.



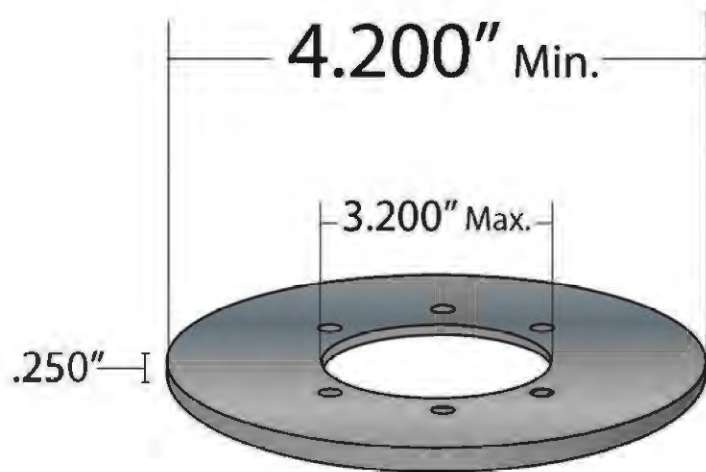

Basket Flange

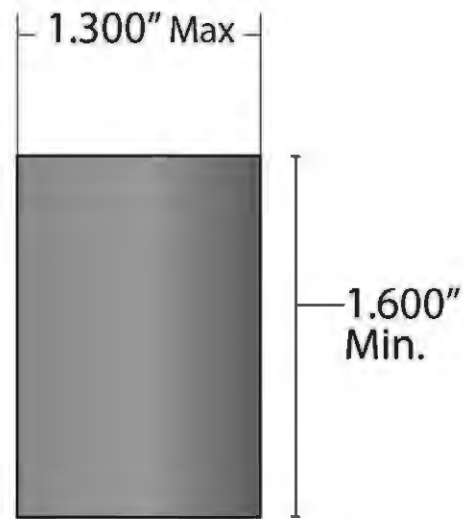

Hub Press Tool

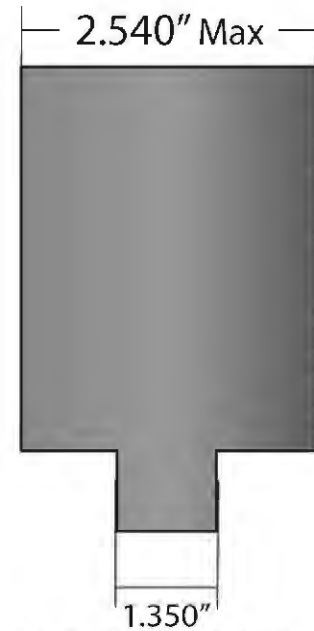

Bearing Press Tool